

NOZZLE SCHEDULE							
ITEM	SIZE	RATING	TYPE	MATL	PROJ IN	PROJ OUT	REMARKS
A	3/4"	N.P.T.	W.F.	C.S.	STD.	STD.	DRAIN
B	2"	N.P.T.	W.F.	C.S.	STD.	STD.	
C	4"	N.P.T.	W.F.	C.S.	STD.	STD.	EMERGENCY VENT OPENING

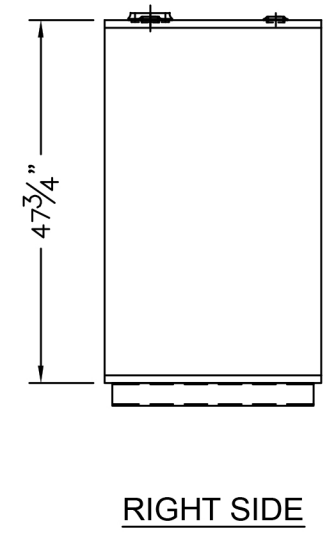
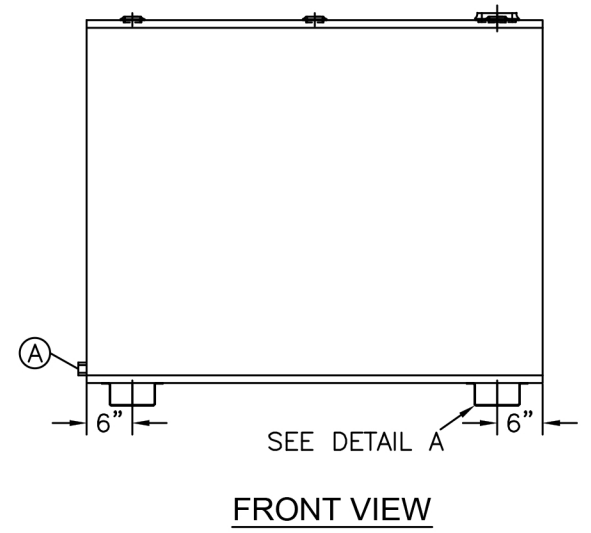
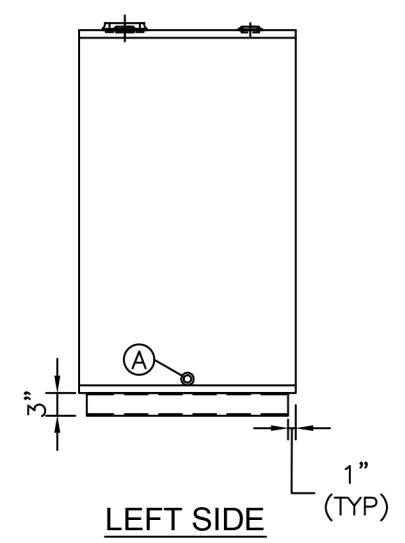

**NOTES:**

- A. Quantity:
- B. Material: H.R. Carbon Steel
- C. Tank: 12 GA w/ 10 GA Top
- D. Design & Operating Pressure: Atmospheric.
- E. Design & Operating Temperature: Ambient.
- F. Tank to be Built & Labeled per U.L. Spec. #142.
- G. Tank to Bear Manufacturers & U.L. Labels Only.
- H. Tank to be Air Tested with Water & Soap Suds Solution.
- I. Interior: Remove Weld Slag (Ship Clean & Dry).
- J. Exterior: Gray primer included; see Sales Order for top coat.
- K. All Fittings to be Protected for Shipment.
- L. Customer has the Responsibility to Verify All Dimensions.

\*All pages of this Schedule A are incorporated by reference and are a part of the additional terms of the Master Terms & Conditions of Sale.

**APPROVAL FOR CONSTRUCTION**  
SCHEDULE A - MASTER TERMS & CONDITIONS OF SALE\*

- APPROVED AS DRAWN.
  - APPROVED WITH NOTED CHANGES, CONSTRUCTION WILL BE SCHEDULED WHEN SIGNED DRAWING AND CONFIRMED ORDER ARE RECEIVED.
- SIGNATURE \_\_\_\_\_  
DATE: \_\_\_\_\_

SALES ORDER # \_\_\_\_\_



VESSEL DESCRIPTION:  
350 GALLON RECTANGULAR UL 142 SINGLE WALL TANK

CUSTOMER:			P.O.#
DATE:	SCALE:	DWG.#	DRAWN BY: TC
		NEFTSBS0350	CHKD. BY: TB